



SIDEWALK, CURB & GUTTER, DRIVEWAY & DRIVE ACCESS APPLICATION

350 Hwy 7, Ste 230 • Excelsior, MN 55331
(952) 653-3674

Permit No. _____

Email permit to: permits@excelsiormn.org

FEE: \$125.00

<p>PROPERTY INFORMATION</p> <p>_____</p> <p style="text-align: center;">Street Address of Improvements</p> <p>_____</p> <p style="text-align: center;">Property Owner</p> <p>_____</p> <p style="text-align: center;">Address of Property Owner</p> <p>_____</p> <p style="text-align: center;">City / State / Zip</p> <p>_____</p> <p style="text-align: center;">E-mail address</p>	<p>CONTRACTOR INFORMATION</p> <p>_____</p> <p style="text-align: center;">Name of Sign Contractor</p> <p>_____</p> <p style="text-align: center;">Street Address of</p> <p>_____</p> <p style="text-align: center;">ContractorCity/State/Zip</p> <p>(_____) (_____) _____</p> <p>Telephone No. Fax No.</p> <p>E-mail address: _____</p> <hr/> <p>Property Owner</p> <p>_____</p> <p style="text-align: center;">Signature of Owner</p>
--	--

Submittal: Submit 2 sets of site/survey plans (verifiable scale) drawn and signed by a professional with proposed improvements.

Property Information: Zoning District: R1 R2 R3 R4 DC CC MU GC P
 Residential Use Commercial Use

	City Code, Appendix E. Art. 36: Gen. Stormwater Mgmt.	Impervious Surface Coverage <u>Maximum</u>
(1)	Low density residential (R1, R2)	27% - 42% (see Article 41)
(2)	Multiple family residential (R3, R4):	40% (see Article 41-6)
(3)	Commercial: (DC, CC, MU, GC)	75% - 100% (see Article 50-3)
		85%

Description of Improvements: **New Install** **Replacement** **Remove**

Sidewalk Curb & Gutter Driveway Driveway Entrance Begin Date: _____ To Be Completed: _____

1.) Driveway width and dimension of drive: _____ feet X _____ feet & Depth _____ inch

2.) Sidewalk width and dimension: _____ feet X _____ feet & Depth _____ inch

3.) Curb & Gutter Type: _____

4.) Location of Improvements on Property: _____ Impervious %: _____ Attach Survey/Site Plan

APPLICANT INFORMATION In signing this application, I hereby acknowledge that I have read and fully understand the applicable provisions of the City Ordinances and current administrative procedures. Signature of this application by the legal property owner or a licensed contractor, as the owner's representative is required and authorizes the City Zoning Administrator or designee and the City Building Official or designee to enter upon the property to perform any inspections. Entry may be without notice. I hereby acknowledge that I have read this application and all information is true and correct to the best of my knowledge. I further agree that all work performed will be in accordance with approved plans, specifications and conditions and to abide by all ordinances of the City and the laws of the State of Minnesota. I further acknowledge the fee explanation and hereby agree to pay all statements received pertaining to additional application expense and city review. Upon review, the City of Excelsior reserves the right to require additional apps./permit(s) and if said determination is made, the applicant will be notified and this permit shall become null and void.

Applicant's Name (printed) _____ Signature _____

Phone No. (_____) _____ Fax No. (_____) _____

Date _____ E-mail address _____

FOR OFFICE USE ONLY	Per Resolution No. 2005-40 11-21-05
Approved: _____	Date: _____
Inspected: _____	Date: _____

SIDEWALK SPECIFICATIONS FOR THE CITY OF EXCELSIOR

This document was created for property owners who wish to use a contractor of their own choosing and contract directly for sidewalk replacement work. In general, property owners are encouraged to utilize the City's flat work contractor for this work but are not required to do so. Property owners who perform their own concrete work or hire a separate contractor to perform the work are responsible for the workmanship and warranty of the work.

Permits

Property owners or their contractors shall be required to secure a permit from the City of Excelsior for construction of sidewalks within its boundary and any applicable permits from Hennepin County or MnDOT to work within the road right-of-way. All work shall meet the City's specification for sidewalk installation.

General Design

The City of Excelsior currently contains sidewalk sections, which vary in width from street to street. While the City has a long-term goal of creating a uniform 5-foot width sidewalk throughout the City, property owners are only required to match the existing adjacent sidewalk widths. In cases where the adjacent sidewalks are of varying width, the new sidewalk should match the widest adjacent sidewalk width.

Along Water Street and commercial areas of the City, the existing sidewalks are in ten (10) foot square sections, which are susceptible to premature cracking and failure. In replacing these sidewalk panels, property owners are allowed to use five (5) foot square panels but first must submit the new panel configurations to the City Engineering staff.

Sidewalk grades shall generally follow the existing topography with a maximum longitudinal grade of 5%. Traverse grades shall be provided to accommodate adequate surface drainage, typically $\frac{1}{4}$ inch per foot fall toward the street.

Depth of Slab

Replacement sidewalk will consist of removal and disposal of existing concrete and placement of new concrete four (4) inches thick. New drive approaches and new sidewalk abutting a driveway approach shall have a minimum of six (6) inches of concrete. Where no boulevard exists between the roadway and sidewalk, a minimum of six (6) inches of concrete shall be placed.

Materials

Only plant manufactured ready mix concrete shall be used. The contractor shall provide, when requested by the City Engineer, a Certificate of Compliance for all concrete used.

Placing and finishing

The subgrade shall be thoroughly moistened, and the concrete shall be poured to the proper depth. The concrete along the edges of the forms and joints shall be spade and the concrete shall be struck off until all voids are removed, and the surface has the required

grade and cross section. The surface shall be floated and troweled just enough to produce a smooth dense surface, free from irregularities. All joints and edges shall be rounded to a radius of ¼ inch with an approved finishing tool.

Curing and Protection

All sidewalk and approach surfaces shall be properly protected from the elements, travel and vandalism for the first 72 hours, except that pedestrian travel may be permitted after 48 hours. All curing compounds shall be clear.

Final Grade and Clean-up

After the concrete has set sufficiently, but not more than three days, the forms shall be removed, and spaces shall be back filled with topsoil. The area between the sidewalk and the property line shall be graded and level as required, to meet the original ground surface. These areas shall also be left free of all rocks, concrete, roots and other debris. Disturbed areas along the length of the sidewalk shall be seeded or sodded at the City Inspector's discretion.

Inspections

Upon placement of the forms and preparation of the subgrade, the contractor shall notify the Excelsior Public Works Department to perform grade and form inspection. The Contractor will be required to make any corrective actions outlined in these requirements. The sidewalk can be poured once the form and grade have been approved.

Traffic Control

The contractor shall perform their work in compliance with the MnDOT Uniform Traffic Control Devices (MUTCD) providing proper traffic control devices for construction as needed.

Trees and Landscaping

Trees located on the private property in part or in total are the responsibility of the property owner and the care and removal of these private trees can be conducted at the property owner's discretion. The recommended sidewalk replacement process requires the cutting and grinding of the tree roots to a depth of six (6) inches below the bottom of the sidewalk.

Excelsior

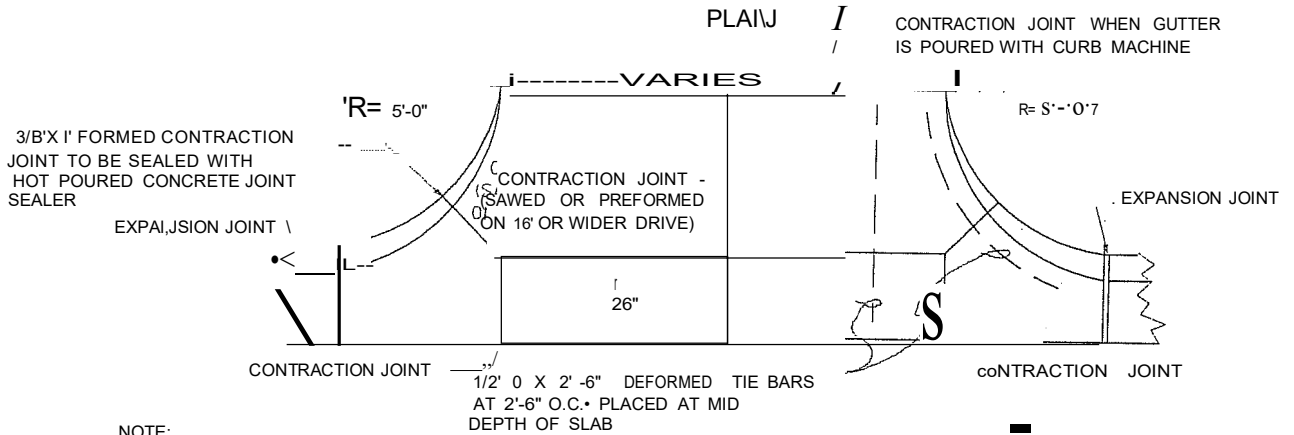
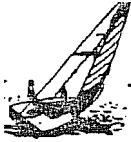

NOTE:
STEEL TO BE USED WHEN DRIVEWAY SLAB IS NOT POURED INTEGRAL WITH GUTTER

NOTE:
WHERE SIDEWALKS EXIST OR ARE PROPOSED, THE DRIVEWAY SHALL EXTEND THROUGH THE SIDEWALK.

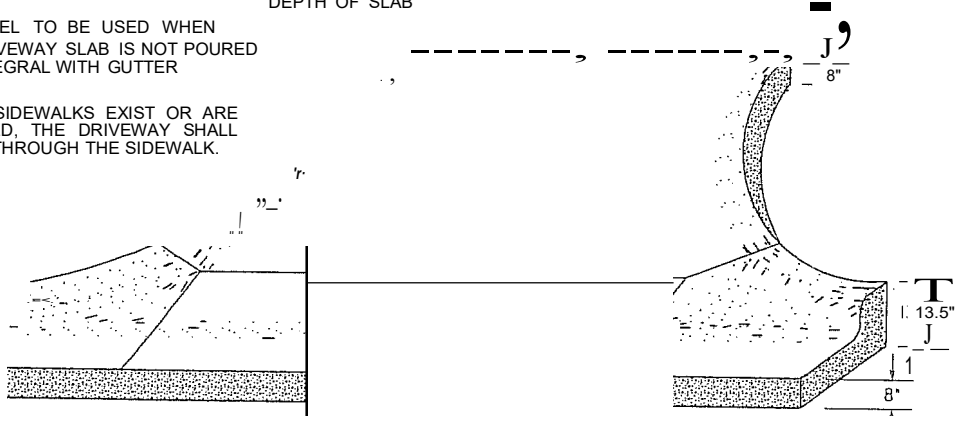

PAYMENT FOR DRIVEWAY SHALL BE FROM BACK OF CURB

SECTION

associates, inc.
 & Associates, Inc.
 701 Xenia Avenue South, Suite 300
 Minneapolis, MN 55416
 www.wsbeng.com
 763-541-8000 Fax/63-541-1700
 INFRASTRUCTURE ENGINEERING PLANNING CONSTRUCTION

**2007 SIDEWALK
 REHABILITATION PROJECT**

Excelsior, Minnesota

WSB Project No. 01140-51 Date: MAY 23, 2007
 Cty Project No.

**Figure Number
 2**

ROW

5', 6', or 10-12'

VARIABLE

2%

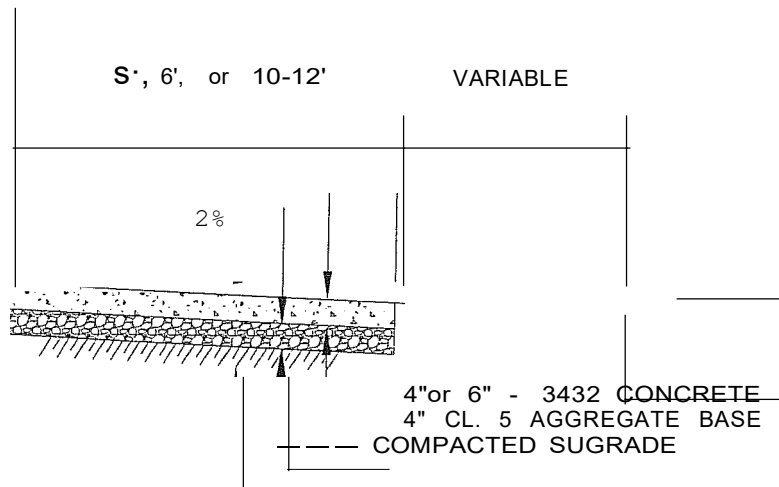

WSB Project No. 01140-51

Date: MAY 23, 2007



701 Xenia Avenue South, Suite 300
Minneapolis, MN 55416
www.wsbeng.com

2007 SIDEWALK REHABILITATION PROJECT

City ProjectNoFigure Number

3

Excelsior, Minnesota